

# CUMSA

INNOVATIVE SOLUTIONS  
FOR YOUR MOLDS

## スライド革命

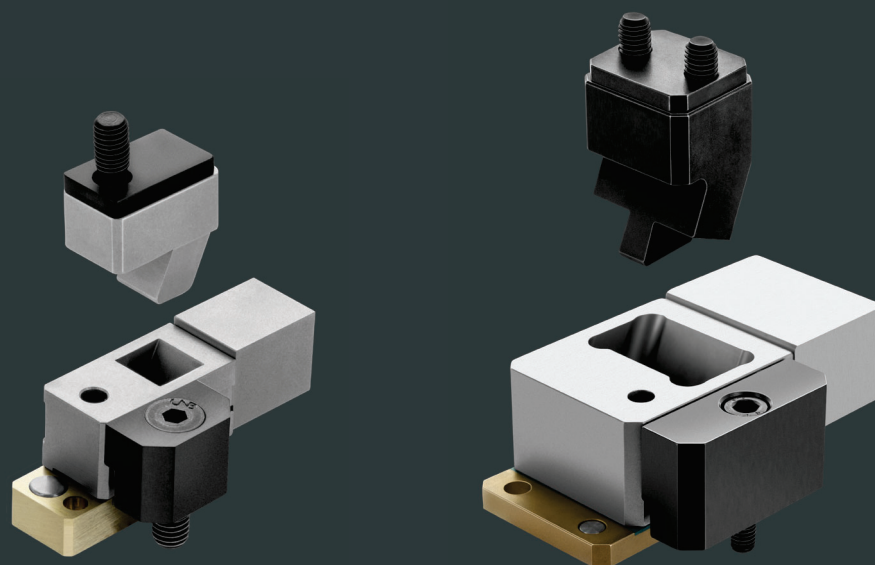

**MS** MINI  
SLIDE

**CS** COMPACT  
SLIDE

INTRODUCING THE NEW  
FLOATING INSERT

# CS

## コンパクトスライド

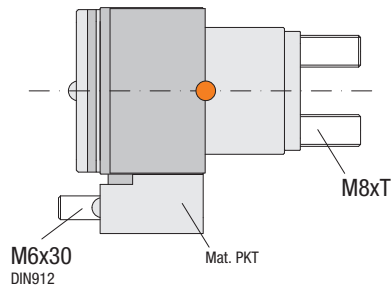
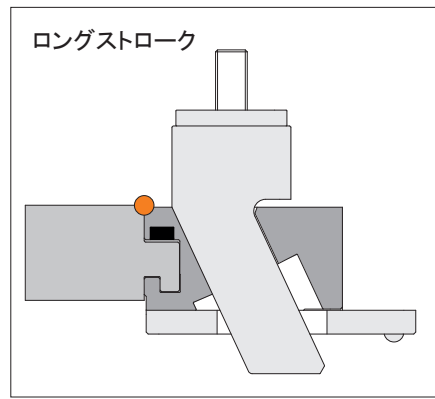
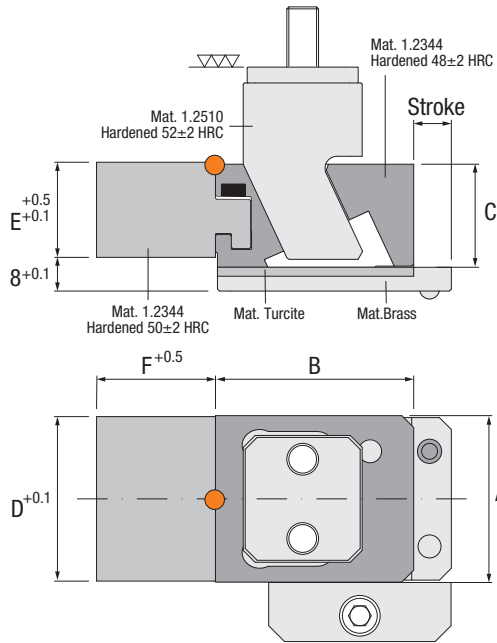

型番	A	B	C	D	E	F	H	J	K	P	Q	N	ストローク	T	U	V	W	Z
CS.423009	42	50	26	41.5	24	30	32.5	60	54	-	-	-	9	55	32	30	24	20
CS.423017	42	50	26	41.5	24	30	32.5	68.5	62.5	17	34	12	17	55	32	30	24	20
CS.523511	52	56	32	51.5	30	35	38.5	69	63	-	-	-	11.5	55	38	34	26	20
CS.523519	52	56	32	51.5	30	35	38.5	76	70	20	35	9	19	55	38	34	26	20
CS.624014	62	62	38	61.5	36	40	44.5	77	72	-	-	-	14	60	44	38	28	24
CS.624022	62	62	38	61.5	36	40	44.5	85	81	23	39	11	22	60	44	38	28	24

### 金型加工寸法

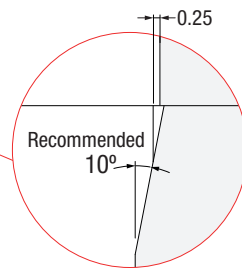
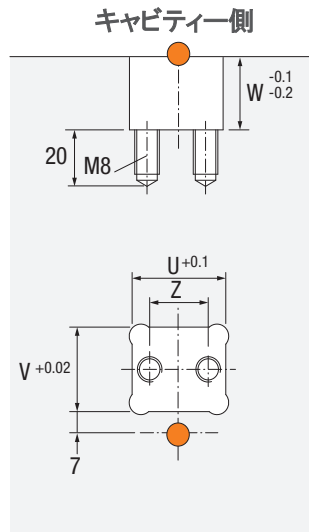
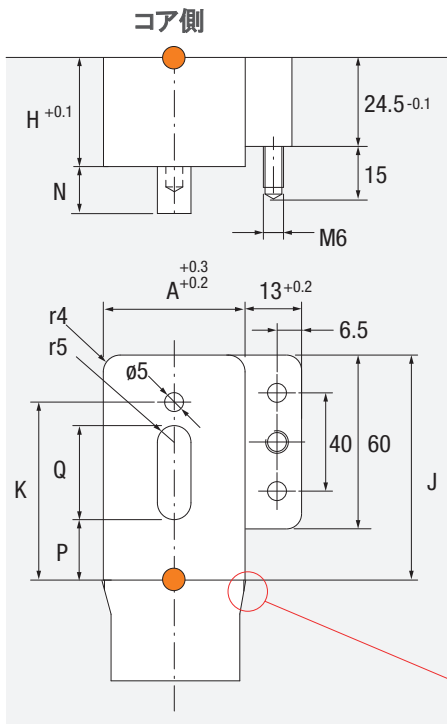

### キャビティー組込み

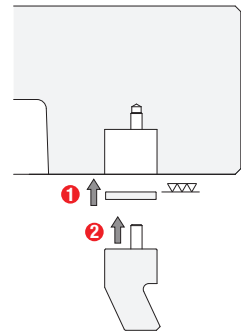

### コア組込み

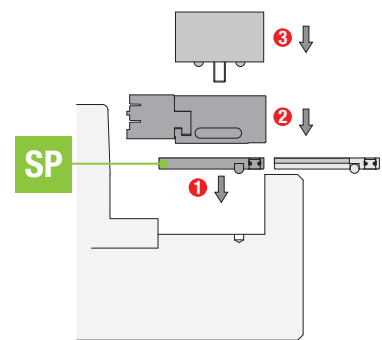

# SP

スライド調整プレート

型番	SP.423009	SP.423017	SP.523511	SP.523519	SP.624014	SP.624022
コンパクトスライド	CS.423009	CS.423017	CS.523511	CS.523519	CS.624014	CS.624022



# ミニスライド

# MS

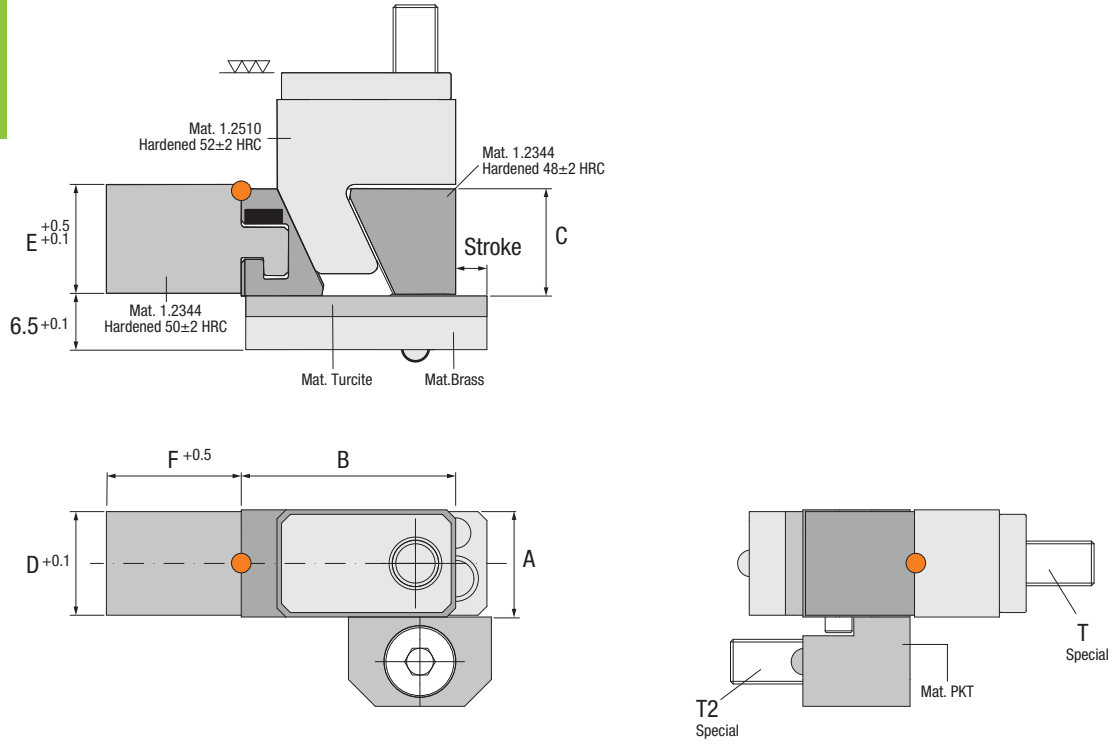

型番	A	B	C	D	E	F	G	H	J	K	L	M	N	R	ストローク	T	T2	U	V	W	X	Z
MS.121503	12	24	12	11.6	12.2	15	12.5	18.5	28	19.5	10	16	5	3	3	M5x20	M5x20	12	20	12.5	4	4.5
MS.182006	18	41	16	17.6	16.5	20	16.5	22.5	47	32.5	16	28	4.5	5	6	M6x40	M5x25	12	26	15.5	7	13
MS.242608	24	45	20	23.6	20.5	26	16.5	26.5	53	38.5	16	28	4.5	5	8	M6x45	M5x25	17	30	16.5	7	15

## 金型加工寸法

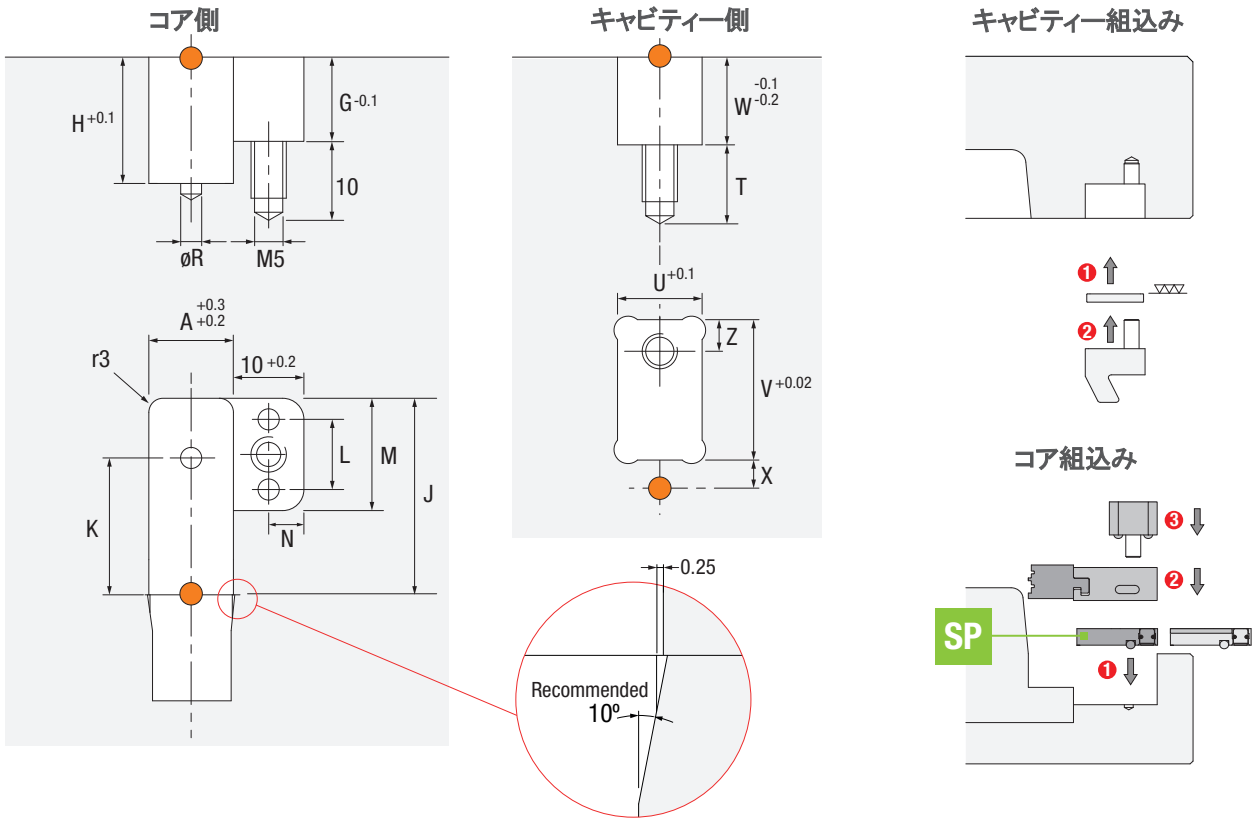

**SP** スライド調整プレート

型番	SP.121503	SP.182006	SP.242608
ミニスライド	MS.121503	MS.182006	MS.242608



## 金型の省スペース化と組込み工数の削減を追求！

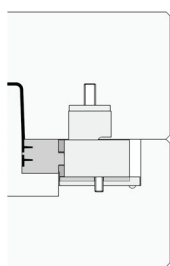

型閉時

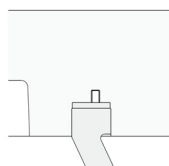
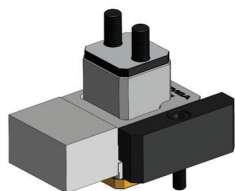

型開時

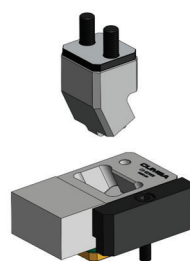

## 金型の組込みスペースを大幅に削減！ 多数個取りに最適！



CUMSA  
コンパクトスライド

標準的な  
スライド

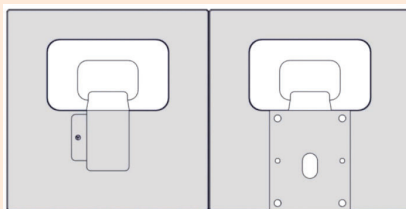

CUMSA  
コンパクトスライド

標準的な  
スライド

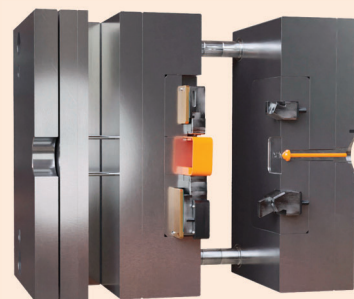

## 金型への組込み時間を1/10以下に短縮



CUMSA  
コンパクトスライド

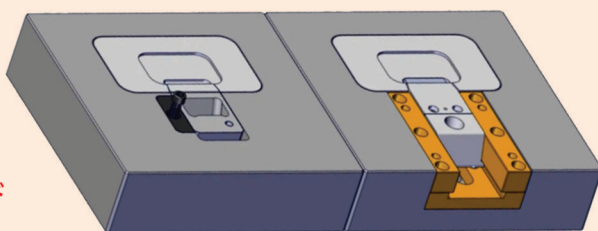

標準的な  
スライド

## 製品部インサートの位置を型内で自動調整可能

